



Mechanical clinching of metal–polymer joints



F. Lambiase*, A. Di Ilio

Department of Industrial and Information Engineering and Economics, University of L'Aquila, Via Campo di Pile, 67100 AQ, Italy

ARTICLE INFO

Article history:

Received 8 April 2014

Received in revised form 1 August 2014

Accepted 9 August 2014

Available online 17 August 2014

Keywords:

Clinching

Hybrid joints

Thermoplastic

Forming

Mechanical joining

ABSTRACT

The present investigation is carried out to assess the suitability of the clinching process for production of plastic–metal hybrid joints. To this end, a prototypal apparatus was developed to preheat the sheets before joining. A campaign of experimental tests was carried out on aluminium alloy AA5053 and polystyrene. Experimental tests were conducted by varying the main process parameters, i.e. pre-heating conditions (heating time and temperature of heating air) and forming pressure. The joints produced under different operating conditions were observed using optical and stereoscope microscope. In addition, the mechanical behaviours of joints were assessed by conducting single lap shear tests on single joints. Based on the achieved results, the main failure modes were identified and the effect of process parameters on mechanical behaviours of the joints were clarified.

© 2014 Elsevier B.V. All rights reserved.

1. Introduction

The concurrent employment of lightweight materials, such as polymers and composites, together with sheet metals, represents a viable solution for weight reduction of vehicles, aimed to limit emissions and fuel consumption in transports.

However, the employment of different materials, often gives rise to joining problems, which requires the development of adequate solutions to the nature of the materials to be joined. To this end, a number of joining processes have investigated in the literature for the production of metal–polymer hybrid joints.

Amancio et al. (2011) have investigated the feasibility of friction spot joining in magnesium/fibre-reinforced polymer composite. Goushegir et al. (2014) have analyzed the microstructure and mechanical performances of friction spot joints made of aluminium AA2024/carbon-fibre reinforced poly (phenylene sulphide) composite. Liu et al. (2014) have investigated the mechanical performances of aluminium–polyamide connections produced by continuous friction lap welding. Blaga et al. (2013) have adopted friction riveting to join glass–fibre-reinforced polyetherimide composite and titanium. This process is based on a local material preheating produced by the interaction of a rotating rivet forced into the materials and the subsequent forging step, which produces a mechanical interlock between the sheets.

Abibe et al. (2013) investigated the mechanical behaviours of hybrid polymer–metal joints made by injection clinching. The process involves a metallic component with a predrilled hole and a thermoplastic component with a stud. The stud is inserted into the metal sheet hole, is softened by preheating and it is subsequently formed by a punch to produce a cap which fastens the two materials.

Recently, Gerstmann and Awiszus (2014) have employed flat clinching to join materials other than metals including plastics and corrugated cardboard. Clinching is an alternative mechanical joining process, which creates a mechanical interlock between two or more sheets by the employment of a relatively simple equipment, mainly constituted by a punch and a die. Clinched joints are produced by a plastic deformation of the components, thus they do not require sheet predrilling (unlike other mechanical joining processes), for this allowing a significant reduction in the joining time. Furthermore, mechanical clinching does not require additional elements such as screws or rivets with a significant reduction of the unit cost. Nevertheless, since the joints are produced by a plastic deformation, the employment of clinching is restricted to non-brittle materials. In addition, because of severe and localized plastic strain which occurs during the joining process, the formability of the punch-sided material can limit the successful employment of this process.

The mechanical behaviours of the joints are influenced by the material flow during the clinching process; therefore, a number of investigations have been carried out in order to assess the effect of the process parameters on the final geometry of clinched joints. Mucha (2011a) has investigated the effect of the process parameters and tools geometries on the mechanical performances of

* Corresponding author at: Montelucio di Roio, 67040 AQ, Italy.

Tel.: +39 0862 434422; fax: +39 0862 434303.

E-mail address: francesco.lambiase@univaq.it (F. Lambiase).

clinched joints using fixed dies. The author (Mucha, 2011b) deeply investigated the effect of sheet thickness on mechanical behaviours of joined components used in automotive. He et al. (2014) compared the mechanical behaviours of clinched and clinched-bonded hybrid joints. Xu et al. (2014) have developed a numerical model involving material damage to avoid the shearing of the sheet in contact with the punch during the clinching joining. Roux and Bouchard (2013) have developed a global optimization procedure including ductile damage of material to optimize the clinching tools geometries. Lambiase has analyzed the effect of the main process parameters on clinching with extensible (split) dies (Lambiase, 2013a).

The present investigation is intended to assess the suitability of the mechanical clinching process to produce plastic–metal hybrid joints. To this end, a prototypal apparatus was developed to perform a convective preheating and the subsequent clinching of the sheets. Clinched joints produced on an aluminium alloy AA5053T4 and polystyrene were investigated. A campaign of experimental tests was carried out to evaluate the influence of the main operational conditions on joinability and mechanical behaviours of

clinched connections. Preheating conditions including heating time and heating temperature, forming pressure and die geometry were varied to identify a suitable joinability window.

Microscopic analysis performed with an optical and a stereo microscopes is carried out to study the cross sections of the joints. SEM micrograph is also utilized to better understand the material flow. Single lap shear tests are used to evaluate the mechanical behaviours of the produced joints.

2. Materials and methods

Aluminium alloy AA5053 of thickness $s = 1.2$ mm and transparent polystyrene (PS) of thickness $s = 1.2$ mm were used to produce metal–plastic hybrid-joints by clinching. According to a series of preliminary tests conducted at room temperature, clinching the above mentioned materials results in polymer rupture with formation of radial cracks; therefore, as also suggested by Gerstmann and Awiszus (2014), preheating of the polymer was adopted.

A schematic representation of the clinching phases as well as the main quality criteria (neck thickness t_n and interlock t_s) is reported

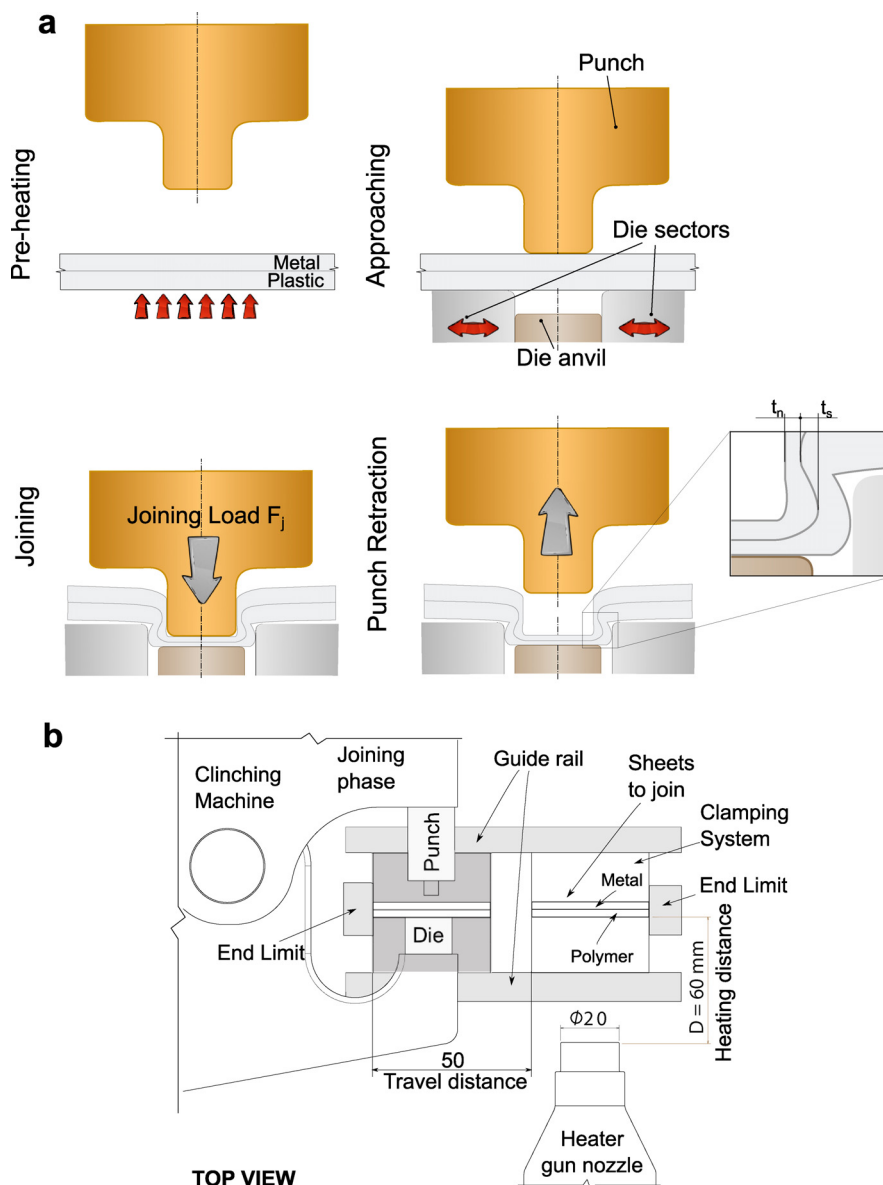

Fig. 1. (a) Schematic representation of preheating and subsequent clinching of thermoplastic and metal sheets. (b) Layout of the experimental equipment.

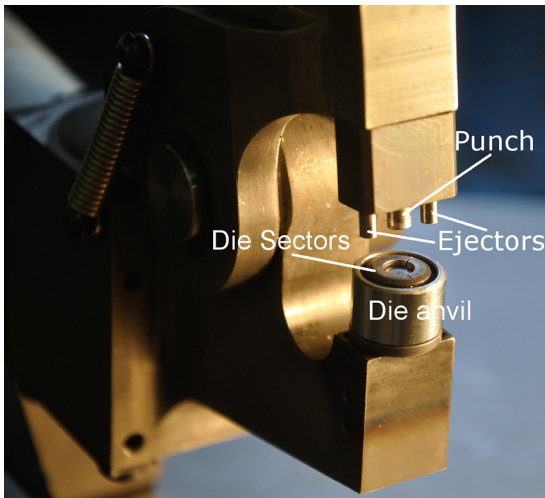

Fig. 2. Picture of the clenching machine used in the experimental tests.

Table 1
Experimental factors and ranges of variation.

Process parameter	Variation range
Depth of die anvil, h [mm]	0.6–0.8
Preheating time, t_p [s]	1–30
Air temperature, T_{air} [°C]	200–400
Joining load, F_j [kN]	7–18

values of the joining load (F_j), six values of the heating time (t_h) and two values of air temperature (T_{air}), as summarized in Table 1.

Two extensible dies were utilized in this investigation. Such dies allow to reduce the forming force as compared to conventional fixed dies as reported in (Lambiase, 2013b; Lambiase and Di Ilio, 2013). In addition, extensible dies allow an easier joint extraction from the die cavity after the clinching operation, compared to the more common grooved dies used for clinching.

The two dies are characterized by the same dimensions except that for the depth of the die anvil, which is $h = 0.6$ mm and 0.8 mm, respectively. A clinching punch, having a truncated cone shape is adopted. Such type of punch allows to easily remove the metal button when aluminium alloys are utilized. A schematic representation of the clinching tools is reported in Fig. 3.

The mechanical characterization of the joints was performed using a single lap shear joint configuration at room temperature using a universal MTS 322.31 testing machine with 25 kN full scale load. The schematic of the single lap shear joint specimen is depicted in Fig. 4. The tests were conducted under displacement

in Fig. 1a. Before each experiment, the polymer and metal sheets are clamped together and placed at the heating position. Convective heating is thus performed by means of a heater gun with a nozzle diameter of 20 mm placed at a distance $D = 60$ mm from the polymer surface. Such a distance was chosen by conducting a series of experimental tests by varying D in the range of 40–120 mm. As expected, the higher the distance, the lower the heating effectiveness; however, since placing the heating gun excessively close to the polymer entailed some space problems, the above mentioned distance resulted in a good compromise. After the preheating, the clamping system is manually moved under the clinching machine, which clinches the sheets immediately. The employment of the guide rails, the end limits and the relatively low distance between the heating and clinching positions (50 mm, as depicted in Fig. 1b), allowed to keep the displacement time to about 0.5 s from the end of heating.

The preheating is performed by means of a common industrial heater gun, model HG651CK by Makita, which allows a good temperature control at the gun head with a maximum air temperature of 650 °C. The preheating time should be chosen to allow the polymeric partner to soften without leading to loss of planarity, distortion even material burning. To this end, differential scanning calorimetry (DSC) tests were carried out on the polymer partner using a DSC 8500 by PerkinElmer. During the clinching process, the softened polymer and the metal partner are forced to fill the die cavity and form a mechanical interlock. At the end of the joining operation, a certain consolidation time is needed (about 1 s) before the punch retraction and the joint extraction from the die.

Different preheating schemes were adopted by changing the heating time and air temperature at the head of the heater gun. The temperature evolution produced with different heating schemes was measured by means of two K-type thermocouples, exhibiting a response time of 0.5 s, placed on the exposed side to heating medium (T1) and the opposite side (T2) of the polymer sheet. Preliminary experimental tests were carried out to determine a feasible heating window to heat up the polymer before the joining operation.

Mechanical clinching was performed by means of a portable machine, model Python (Jurado, Rivortorto di Assisi, Italy), depicted in Fig. 2, which allows a maximum forming force of 22 kN.

Different combinations of process parameters were tested to determine the joinability window and the influence of the process conditions on the mechanical behaviours of the joints. Clinched connections were performed by adopting two different dies, five

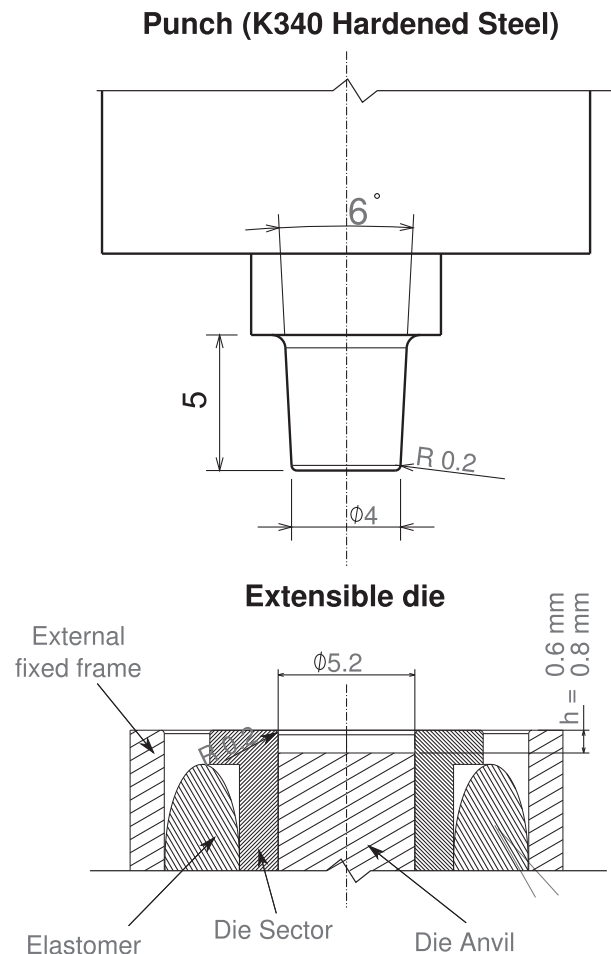

Fig. 3. Schematic representation of adopted clinching tools.

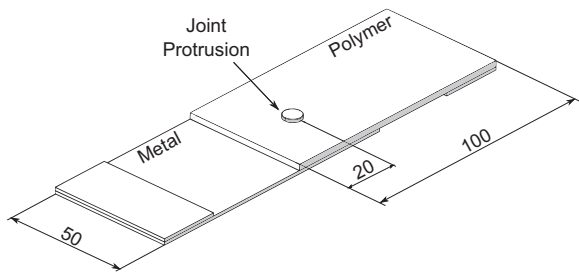

Fig. 4. Schematic representation of the shear lap sample with single joint. Dimensions are expressed in millimetres.

control at 0.2 mm/min. The tests were stopped after the complete separation of the sheets.

Optical and stereoscopic microscopy as well as Scanning Electron Microscopy (SEM) with relatively low magnifications were used to observe the joints and the cross section profiles produced under different operating conditions.

3. Results and discussion

3.1. Analysis of temperature

DSC tests on the polystyrene sheets material allowed to evaluate the glass transition temperature of the polymer $T_g = 105^\circ\text{C}$, as reported in Fig. 5. The temperature produced with different heating schemes by varying the temperature of heating air and preheating time are also reported in the same figure. For each heating condition, three replicates were conducted. As can be inferred, the two sides of the polymer experience very different temperatures. The die-sided surface, which is directly exposed to the heating air-flow shows a significant increase in temperature (T_1), while the opposite side (T_2) shows only marginal increase in temperature (except when heated with air temperature of 400°C and for pre-heating times longer than 5 s). According to the results showed in Fig. 5, the temperature of the die-sided material steeply increases with pre-heating time (t_h) for low values of preheating time. However, for larger values of t_h , the temperature T_1 saturates after almost 15 s, and longer preheating times mainly result in an increase of temperature of the opposite side.

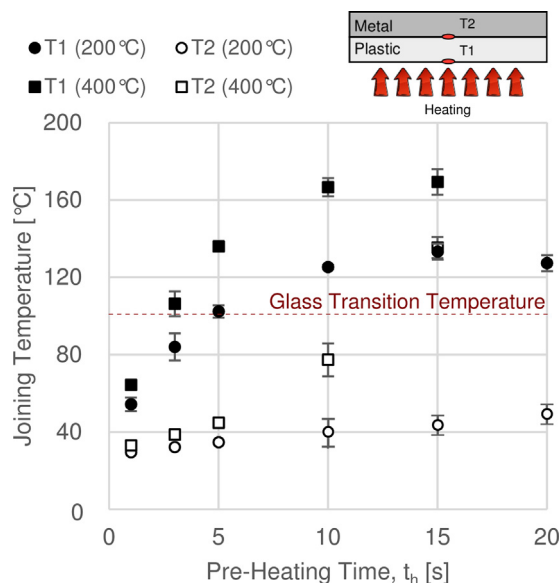

Fig. 5. Variation of joining temperature with pre-heating time and temperature of heater.

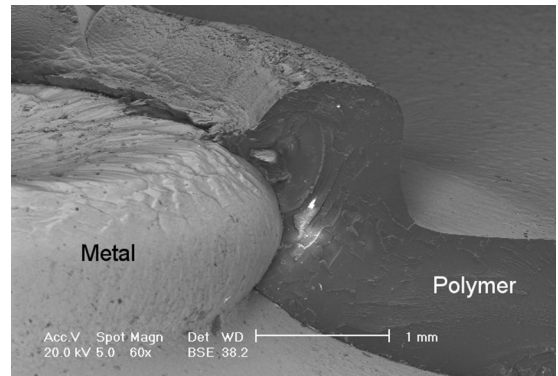

Fig. 6. SEM macrograph of a clinched connection produced with $T_{\text{air}} = 400^\circ\text{C}$, $t_h = 2\text{ s}$ and joining load $F_j = 11\text{ kN}$.

3.2. Material flow

Scanning electron microscopy was used to analyze the material flow and possible imperfections in both the metal and polymer sheets.

Fig. 6 depicts the SEM macrograph of a metal–polymer joint produced by clinching, corresponding approximately to the zone circled in red in Fig. 7. As can be seen, the polymer has completely spread away from the centre of the joint. Indeed, because of the difference in the yield strength of the polymer and the metal, the high axial compressive stress developing during the upsetting phase mainly spreads the polymer radially. At the end of the joining process, a thin layer of polymer lays on the joint bottom that is often torn out during the extraction of the joint from the die. In Fig. 6, the lighter component is the aluminium while the darker is the

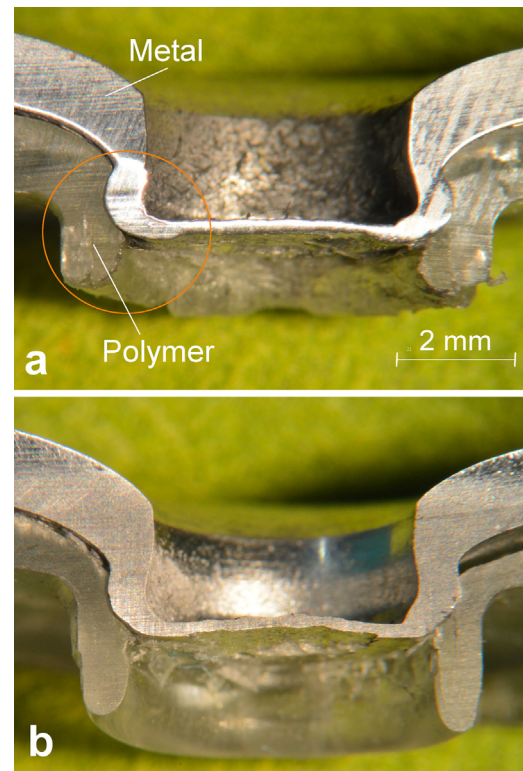

Fig. 7. Cross section of polymer–metal clinched connections produced with air temperature $T_{\text{air}} = 400^\circ\text{C}$ with different heating times (a) $t_h = 2\text{ s}$ and (b) $t_h = 10\text{ s}$. (For interpretation of the references to colour in this figure citation in the text, the reader is referred to the web version of this article.)

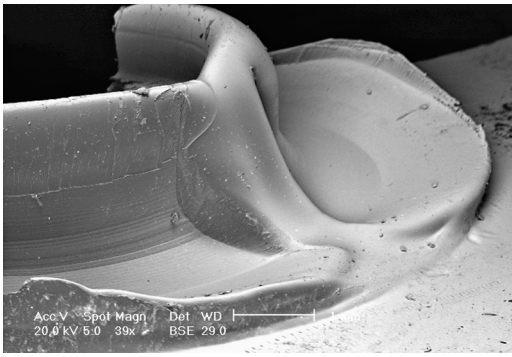

Fig. 8. Macrograph of polymer (die-sided sheet) in a clinched connection with excessive preheating.

metallized polymer. As can be seen, the material flow produced by clinching leads to the development of a mechanical interlock between the two materials.

According to the experimental observations, the material flow, as well as the characteristics of the clinched joints, i.e. the neck thickness and the interlock, were highly influenced by the polymer temperature achieved by preheating. The formation of clinched connections is based onto the material flow produced during the offsetting and subsequent upsetting phases. In conventional clinching of metal sheets, the upper sheet (punch-sided) flows along the lower sheet to form the typical S-shaped connection.

Excessive preheating leads to a drastic reduction in the polymer viscosity, therefore, the polymer underlying the metal sheet round corner is pushed towards the die interstices and the upper knee of the S-connection is partially reduced. As a result, a small interlock is formed between the metal and the polymer. The excessive softening in the polymer sheet yields similar material flow as produced when a large punch-die clearance is adopted in conventional clinching of metals (Lambiase, 2013a).

Fig. 7 depicts the cross sections of polymer–metal clinched connections produced with different heating times.

The adoption of a prolonged preheating induces high softening in the polymer component, which deeply penetrates between the die sectors interstices, as shown in Fig. 8. This behaviour has a negative effect on the process due to the increase in the consolidation time. In addition, during the punch retraction phase, a lower polymer viscosity can result in a partial or complete detachment of the metal sheet from the polymer.

3.3. Joinability

In this section, the effect of the main process parameters on joint formation is discussed.

During the production of clinched connections, the upper sheet, which is in contact with the punch, is subjected to large deformation (Roux and Bouchard, 2013). The deeper the die anvil, the higher the strain concentration at the neck of the metal button (Lambiase, 2013a). As a result, the employment of the deeper die ($h = 0.8$ mm) led to unsuccessful joining. Indeed, when the joining load was lower than 9 kN, the metal interlock was not formed; on the other hand, for higher joining loads, the metal button resulted completely sheared, regardless the preheating conditions adopted, as shown in Fig. 9b.

The employment of the die anvil with the lower depth ($h = 0.6$ mm) allowed to reduce the strain at the button neck. The joinability plots for the latter die are depicted in Fig. 10. Herein, the successful joining conditions are represented by green circles, overheating conditions are depicted with orange circles and unsuccessful joining cases are indicated with red cross marks.

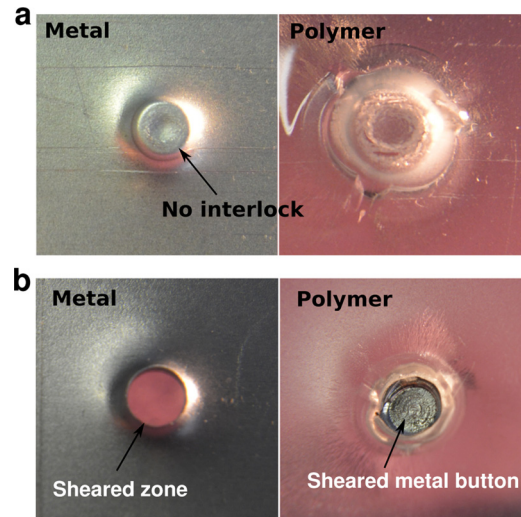

Fig. 9. Failures behaviours occurring during clinching: (a) insufficient forming load and (b) shearing of the metallic button.

According to the achieved results, the joining load shows a threshold values of 9 kN below which the interlock is not formed, as shown in Fig. 10. The threshold value was independent of the pre-heating conditions. Actually, the joining force mainly depends on the flow stress of the metal sheet, which is at least one order of magnitude higher than that of the softened polymer. Therefore, the decrease in the yield stress of the polymer achieved with a prolonged heating time or a higher temperature T_{air} does not alter the minimum required joining load during clinching.

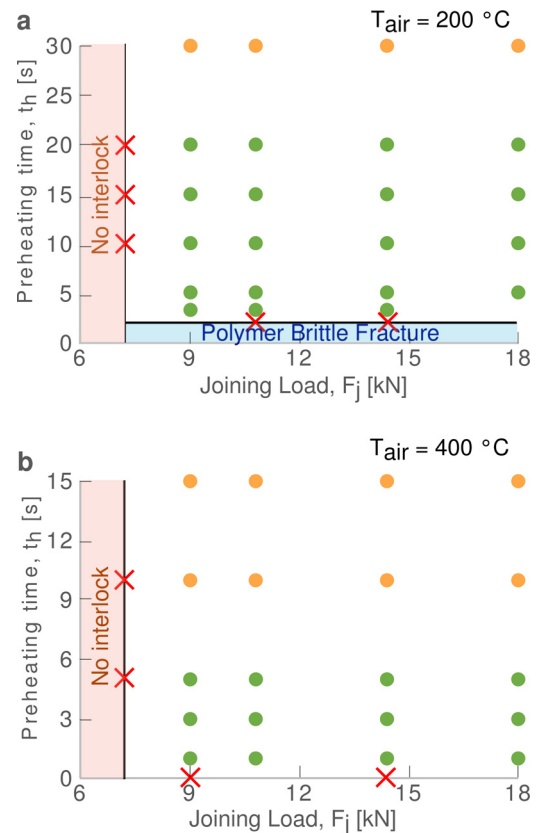

Fig. 10. Joinability window with different temperature of heating air T_{air} . (For interpretation of the references to colour in this figure citation in the text, the reader is referred to the web version of this article.)

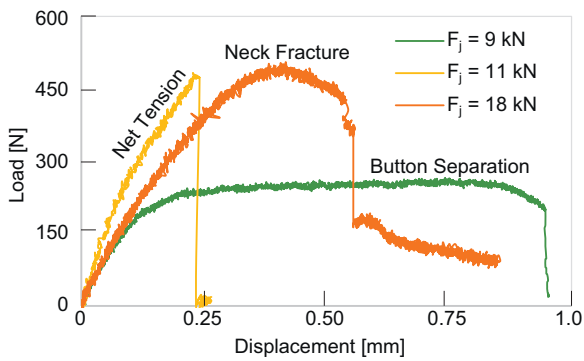

Fig. 11. Load displacement curve for pull-out, neck fracture and net tension failure modes.

Preliminary tests performed at room temperature resulted in polymer sheet fracture in radial direction. During the first phase of clinching (offsetting), the polymer is mainly subjected to tensile stress developing in radial direction. On the other hand, during the upsetting phase, the polymer is subjected to tensile stress in circumferential direction with high magnitude, as observed in (Lambiase, 2013a). In order to prevent brittle rupture in the polymer sheet, opportune preheating should precede the clinching operation, as also suggested in (Gerstmann and Awiszus, 2014). According to Fig. 10, the minimum heating time allowing to join the sheets was 3 s for $T_{\text{air}} = 200^\circ\text{C}$ and 1 s for $T_{\text{air}} = 400^\circ\text{C}$.

On the other hand, excessive preheating has detrimental effects on the joint quality and joining process productiveness (since the increase in the consolidation time). The occurrence of such conditions was observed for heating times higher than 30 s ($T_{\text{air}} = 200^\circ\text{C}$) and 5 s ($T_{\text{air}} = 400^\circ\text{C}$), respectively.

The analysis of feasible joining temperature achieved under different joining conditions reveals that successful clinching can be performed at temperatures between 55°C and 65°C , which are much lower than the polymer glass transition temperature T_g . On the other hand, in order to avoid excessive polymer softening, the joining temperature should not exceed 130°C .

3.4. Mechanical behaviour

Clinched connections produced under different processing conditions exhibited different failure modes which are common to clinched connections of metal components as well as spot joints performed on polymer sheets.

Button separation fracture mode is typical of connections produced by clinching when relatively low forming loads ($F_j = 9\text{ kN}$) are adopted (Coppieters et al., 2012). Such rupture mode was also observed on clinched connections with excessive preheating which produced small interlocks. The load–displacement curve of such joints, depicted in Fig. 11 is characterized by low value of the maximum strength due to the small value of the interlock. Herein, the load increases rapidly up to reach a peak followed by a plateau due to the rigid rotation of the plastic around the metal button.

The increase in the joining force (e.g. $F_j = 11\text{ kN}$) results in an increase of the interlock and in turn it produces a joint with higher strength. In polymer–metal clinched connections, a brittle rupture in the polymer that takes place perpendicularly to the pulling direction is observed. Such failure mode, called net tension (Fig. 12a) according to ASTM D5961 (ASTM:D5961), affects the displacement at failure during shear tests. After reaching the peak, the load drops suddenly with the complete loss of load carrying capability.

Neck fracture mode (Fig. 12b) was observed on samples joined with higher forming loads ($F_j = 18\text{ kN}$). The development of such a fracture mode is due to a large interlock between the sheets and a

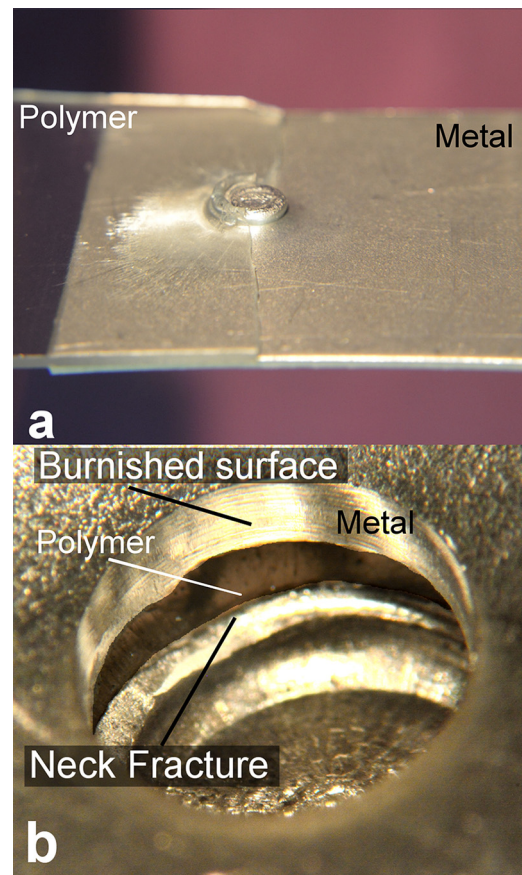

Fig. 12. Rupture modes: (a) net tension of plastic; (b) neck fracture of metal.

relatively thin neck of the metal sheet (the one in contact with the punch) as reported in (Xu et al., 2014). The excessive thinning of the button neck of clinched connection can be produced either by a low formability of the upper sheet material, or an excessive depth of the die anvil or an excessive thickness of the lower sheet. The rupture of the connection is due to the damage development and subsequent crack propagation at the joint neck (He et al., 2014).

The development of neck fracture can be facilitated by the presence of pre-existing cracks at the neck produced during the clinching operation. Local cracks at the button neck can develop much easier on hybrid polymer–metal joints than on metal–metal joints due to a lower enveloping effect exerted by the polymer on the metal during the upsetting phase as shown in Fig. 13. Herein, the red arrows indicate the material flow, which tend to enlarge the crack at the button neck.

For clinched connections experiencing neck fracture failure mode, the load–displacement curve shows a peak which is followed by a gradual reduction caused by the progressive thinning and intrados pressure of the metal button. Unlike other cases, the load is still sustained by the metal button.

The main difference among these cases, apart from the maximum strength, is the displacement at fracture. Net tension develops much faster and the displacement occurs at the expenses of the polymeric component; unbuttoning is more gradual, because after reaching the load peak, an almost rigid rotation occurs leading to a much higher value of displacement. Neck fracture happens more gradually than net tension due to the progressive ductile damage in the metal component.

Fig. 14 shows the effect of the joining force F_j on the shear strength of clinched connections produced using a preheating time $t_h = 20\text{ s}$ and air temperature $T_{\text{air}} = 200^\circ\text{C}$. As can be seen, a

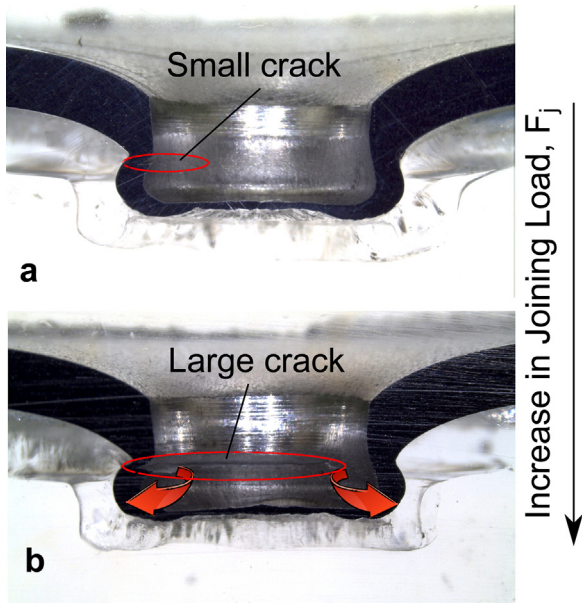

Fig. 13. Crack development in metal sheet neck: (a) $F_j = 14$ kN, (b) $F_j = 18$ kN. (For interpretation of the references to colour in this figure citation in the text, the reader is referred to the web version of this article.)

threshold of the joining force $F_j = 9$ kN exists, below which any interlock is produced, as can be seen in Fig. 14b.

The joints produced with $F_j 9$ kN failed by unbuttoning since the limited size of the interlock resulting in relatively weak mechanical behaviours (the maximum strength $F_{max} = 250 \pm 70$ N). Increasing the joining force up to 10.8 kN resulted in a larger interlock, as depicted in Fig. 14b, with a consequent increase in the joint load-bearing capability. The increase in interlock caused a raise in the force up to $F_{max} = 500 \pm 100$ N and a change in the failure mechanics to net tension in the polymer sheet. Further increase in

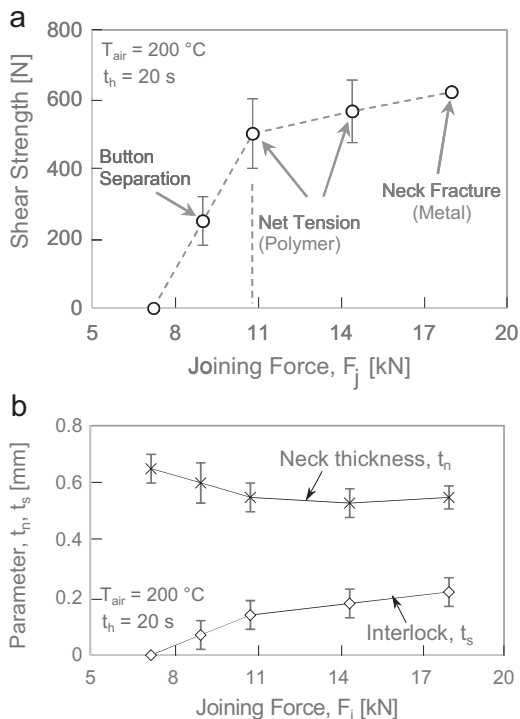

Fig. 14. Effect of joining force on (a) shear strength and (b) interlock and neck thickness.

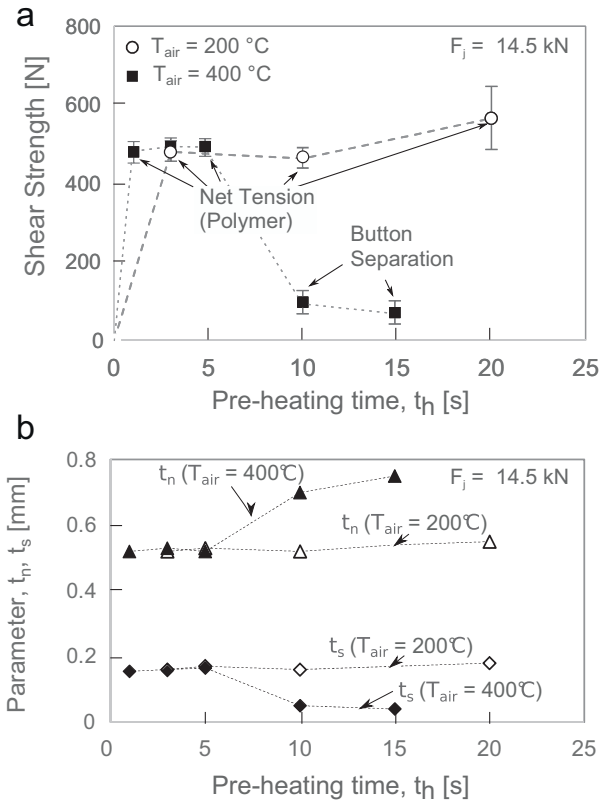

Fig. 15. Effect of pre-heating time on (a) shear strength and (b) interlock and neck thickness.

the joining force up to $F_j = 18$ kN affected the maximum strength of the joint and failure mode negligibly. On the other hand, an excessive increase of joining force resulted in a thinning effect of the button neck and crack development. Therefore, the adoption of a joining force $F_j = 18$ kN resulted in a change in the failure mechanism to neck fracture because of the crack raise at the metal neck, as depicted in Fig. 13. Similar results were found when using a preheating temperature of 400 °C and $t_h = 3$ s.

Fig. 15a and b depicts the effect of the heating time on shear strength and the joints main characteristics (i.e. t_n and t_s) respectively when using a joining force $F_j = 14.5$ kN and both values of air temperature $T_{air} = 200$ °C and 400 °C. As can be seen, when using air temperature of 200 °C, an increase in the preheating time from the threshold value (3 s) resulted in a marginal variation of the shear strength (except for $t_h = 20$ s) for which it was shown an increase in the joint strength (from 480 ± 30 N to 650 ± 80 N) accompanied by a negligible variation of t_n and t_s . The different behaviour exhibited by the joint produced with $t_h = 20$ s can be probably addressed to major plastic behaviour of the polymer at the joint neighbours with a lower formation of microcracks.

The joints produced with air temperature of 400 °C (with up to 5 s of preheating) showed similar mechanical strength, rupture mode (net tension) and quality criteria (t_n and t_s) as the joints produced with $T_{air} = 200$ °C. However, longer pre-heating times resulted in lower strength of the joints due to the reduction of the interlock, as showed in Fig. 15b. Under such conditions, the softened polymer exhibits almost totally loss of any carrying load capability, therefore, during the offsetting phase, the polymer is much highly spread away from the joint resulting in a smaller interlock. Similar conditions were found by Abe et al. (2012) when joining by clinching a high strength steel (on the punch-side) and aluminium alloy (at the die side).

4. Conclusions

In this study, the suitability of mechanical clinching for production of hybrid metal–polymer joints has been investigated. The main process parameters influencing the joinability and the mechanical performances of joints have been identified. Based on the achieved results, the following considerations have been drawn:

- according to the choice of the preheating conditions (preheating time and temperature of hot air), three different scenarios can be identified: (i) insufficient pre-heating (the temperature of the irradiated surface lower than 55 °C) which results in polymer brittle breakage during the joining phase; (ii) proper preheating (the temperature of the irradiated surface is comprised between 55 and 130 °C) which confers to the polymer a sufficient plasticity to be formed without cracks; (iii) excessive preheating (large portion of the polymer thickness in the heated zone has almost reached the glass transition temperature): under such conditions the polymer has been excessively softened leading to the production of small interlocks and weak mechanical behaviour of hybrid clinched connections. In addition it leads to complications during the extractions of the polymer from the die;
- according to the choice of the joining load F_j , four scenarios have been observed: (i) joining load lower than the threshold value ($F_j < 9$ kN): the interlock is not formed; (ii) insufficient joining load (9 kN $< F_j < 11$ kN): the interlock is formed but is relatively small and the joints separate by unbuttoning during the shear tests; (iii) proper joining load (11 kN $< F_j < 18$ kN): the interlock is properly formed and the joints fail by brittle rupture of the polymer during the shear tests; (iv) excessive forming load ($F_j > 18$ kN): a large crack in the metal component load is observed.
- the threshold in the joining force is not influenced by the preheating conditions since negligible variation (compared to melting temperature) of the aluminium sheet temperature (from which depends the required joining load) is produced.
- the analysis of preheating time revealed that compared to conventional joining processes, clinching allows to highly reduce the joining time. Indeed, sound joints were produced with very small heating times resulting into an overall joining time (heating + joining) as low as 2 s;
- compared to clinching of metal sheets, the joining of metal–polymer clinched connections shows additional limitations since the lower enveloping effect exerted by the polymer during the upsetting phase which eases crack formation and development at the button neck.

Acknowledgements

The authors would like to thank Jurado (Rivortorto di Assisi, Italy) and CAMS (Chieti, Italy) for providing the extensible dies and the customized punch used in this research. The authors would also like to thank Mr. G. Organtini (DIIIIE – University of L'Aquila) for his contribute during the setup and conduction of the experimental tests.

References

- 2008. ASTM Committee Standard Test Method for Bearing Response of Polymer Matrix Composite Laminates (D5961M-08).
- Abe, Y., Mori, K., Kato, T., 2012. Joining of high strength steel and aluminium alloy sheets by mechanical clinching with dies for control of metal flow. *J. Mater. Process. Technol.* 212, 884–889.
- Abibe, A.B., Amancio-Filho, S.T., dos Santos, J.F., Hage, E., 2013. Mechanical and failure behaviour of hybrid polymer–metal staked joints. *Mater. Design* 46, 338–347.
- Amancio-Filho, S.T., Bueno, C., dos Santos, J.F., Huber, N., Hage, E., 2011. On the feasibility of friction spot joining in magnesium/fiber-reinforced polymer composite hybrid structures. *Mater. Sci. Eng. A* 528, 3841–3848.
- Blaga, L., Bancilă, R., dos Santos, J.F., Amancio-Filho, S.T., 2013. Friction Riveting of glass–fibre-reinforced polyetherimide composite and titanium grade 2 hybrid joints. *Mater. Design* 50, 825–829.
- Coppieters, S., Lava, P., Baes, S., Sol, H., Van Houtte, P., Debruyne, D., 2012. Analytical method to predict the pull-out strength of clinched connections. *Thin-Walled Struct.* 52, 42–52.
- Gerstmann, T., Awiszus, B., 2014. Recent developments in flat-clinching. *Comput. Mater. Sci.* 81, 39–44.
- Goushegir, S.M., dos Santos, J.F., Amancio-Filho, S.T., 2014. Friction spot joining of aluminum AA2024/carbon-fiber reinforced poly(phenylene sulfide) composite single lap joints: microstructure and mechanical performance. *Mater. Design* 54, 196–206.
- He, X., Zhao, L., Yang, H., Xing, B., Wang, Y., Deng, C., Gu, F., Ball, A., 2014. Investigations of strength and energy absorption of clinched joints. *Comput. Mater. Sci.*, in press.
- Lambiase, F., 2013a. Influence of process parameters in mechanical clinching with extensible dies. *Int. J. Adv. Manuf. Technol.* 66, 2123–2131.
- Lambiase, F., 2013b. Optimization of shape rolling sequences by integrated artificial intelligent techniques. *Int. J. Adv. Manuf. Technol.* 68, 443–452.
- Lambiase, F., Di Ilio, A., 2013. Finite element analysis of material flow in mechanical clinching with extensible dies. *J. Mater. Eng. Perform.* 22, 1629–1636.
- Liu, F.C., Liao, J., Nakata, K., 2014. Joining of metal to plastic using friction lap welding. *Mater. Design* 54, 236–244.
- Mucha, J., 2011a. The analysis of lock forming mechanism in the clinching joint. *Mater. Design* 32, 4943–4954.
- Mucha, J., 2011b. Joining the car-body sheets using clinching process with various thickness and mechanical property arrangements. *Arch. Civil Mech. Eng.* 11, 135–148.
- Roux, E., Bouchard, P.O., 2013. Kriging metamodel global optimization of clinching joining processes accounting for ductile damage. *J. Mater. Process. Technol.*
- Xu, F., Zhao, S.D., Han, X.L., 2014. Use of a modified Gurson model for the failure behaviour of the clinched joint on Al6061 sheet. *Fatigue Fract. Eng. Mater. Struct.* 37, 335–348.